



# GLC65 Commercial/GLM65 Medical 65 Watt Multiple Output Global Performance Switchers



## SPECIFICATIONS:

### Ac Input

90-264 Vac, 47-63 Hz single phase

### Output Power

Total continuous output power is 60 W, 75 W peak for 60 s 10% duty cycle. Total continuous rating with 150 LFM of air is 70 W.

### Input Current

Units are exempt from input current harmonic requirements of EN61000-3-2 when output power is less than 62W. Maximum input current at minimum input voltage and output overload will be less than 2.0 A.

### Inrush Current

Inrush is limited by internal thermistor. The inrush at 240 Vac, averaged over the first ac half-cycle under cold start conditions will not exceed 37 A.

### Input Protection

Internal AC fuse provided on all units. Designed to blow only if a catastrophic failure occurs in the unit -- Fuse does not blow on short circuit or unsustained overload.

### Holdup Time

Output voltage stays within regulation for 20 ms from loss of ac input at 65 W load, from 120 Vac input.

### Efficiency

80% typical.

### Overload Protection

Fully protected against short circuit and output overload. Short circuit protection is cycling type power limit and will automatically recover after removal of fault.

### Overvoltage Protection

Built in with firing point set. OVP firing reduces output to less than 50% of nominal voltage in less than 50 ms.

### Output Noise

0.5% rms, 1% pk-pk, 20 MHz Bandwidth, differential mode. Measured with scope probe directly across output terminals of the power supply with load terminated with 1µF capacitor.

### Transient Response

Main Output - 500 µs typical response time for return to within 0.5% of final value for a 50% load step within the regulation limits of minimum and maximum load,  $\Delta i/\Delta t < 0.2 \text{ A}/\mu\text{s}$ . Maximum voltage deviation is 3.5%.

## FEATURES:

- 65 Watt Wide Range Input
- High Efficiency (Up to 90%)
- Universal input 90-264 Vac
- 2-year warranty
- Also available in single outputs
- Conducted EMI exceeds FCC Class B and CISPR 22 Class B (Commercial models) and CISPR 11 Class B (Medical models)
- Exempt from line harmonics standard EN61000-3-2
- Commercial Approved to UL1950, CSA-C22.2 No. 950, EN60950
- Medical Approved to UL2601-1, CSA 22.2 No. 601.1, and EN60601-1
- **CE** marked to LVD

### Minimum Load

No minimum load required on any output. However, regulation limits may be exceeded if extreme conditions are applied. Contact factory for assistance.

**Temperature Coefficient:** 0.03%°C typical on all outputs.

### Voltage Adjustment

Units provided with potentiometer capable of a minimum adjustment range of +/- 5% from nominal setting.

### EMI / EMC Compliance:

All models include built-in EMI filtering to meet the EMC requirements of IEC601-1-2.

Performance	EMC Standard
Conducted Emissions GLC65	EN55022, Class B; FCC Class B
Conducted Emissions GLM65	EN55011, Class B; FCC Class B
Static Discharge	EN61000-4-2, Level 3
RF Field Susceptibility	EN61000-4-3, Level 3
Fast Transients / Bursts	EN61000-4-4, Level 3
Surge Susceptibility	EN61000-4-5, Level 3
Conducted RF Susceptibility	EN61000-4-6, 3V, 80%
Voltage Sags & Surges	EN61000-4-11
Line Frequency Harmonics	EN61000-3-2 Class A (>62Wout) Exempt (<62Wout)

### GLC65 Commercial - Safety

Condor DC Power Supplies, Inc. declares under our sole responsibility that all models are in conformity with the applicable requirements of EN60950 following the provisions of the Low Voltage Directive 73/23/EEC. All models are approved to UL1950 (with no D3 deviations), CSA22.2 No. 950-95 3rd edition, Level 3, IEC950, EN60950. CB certificate available.

### Commercial Leakage Current

Less than 500 µA @ 120 Vac. Less than 1.2 mA @ 240 Vac.

### GLM65 Medical - Safety

Approvals: All models are certified to be in compliance with the applicable requirements of UL2601-1, CSA 22.2 No. 601.1, IEC 601-1 (1988), EN 60601-1: 1990.

### Medical Leakage Current

40 µA under normal conditions (132 Vac @ 60 Hz). Maximum under single fault conditions (264 Vac @ 60 Hz) is 170 µA.

# GLC65 Commercial/GLM65 Medical 65 Watt Multiple Output

Commercial Model	Medical Model	Output No.	Output	Output Maximum (A)	Output Maximum (B)	Total Regulation (E)	V1 Adjustment Note (C)	OVP Setpoint	Ripple/ Noise
GLC65A	GLM65A	1	+5.0 V	7 A	9 A	2%	± 5%	6.2 ± 0.6 V	1%
		2	+12 V	3 A	5 A	5%	--	--	1%
		3	-12 V	2.5 A	4 A	6%	--	--	1%
GLC65B	GLM65B	1	+5.1 V	7 A	9 A	2%	± 5%	6.2 ± 0.6 V	1%
		2	+15 V	2.5 A	4 A	4%	--	--	1%
		3	-15 V	2 A	3 A	5%	--	--	1%
GLC65D	GLD65D	1	+5.0 V	7 A	9 A	2%	± 5%	6.2 ± 0.6 V	1%
		2	+24 V	1.5 A	2.5 A	3%	--	--	1%
		3	-12 V	2.5 A	4 A	6%	--	--	1%
GLC65E	GLM65E	1	+5.0 V	7 A	9 A	2%	± 5%	6.2 ± 0.6 V	1%
		2	+24 V	1.5 A	2.5 A	3%	--	--	1%
		3	+12 V	2.5 A	4 A	6%	--	--	1%
GLC65G	GLM65G	1	+5.0 V	5 A	8 A	3%	± 5%	6.2 ± 0.6 V	1%
		2	+3.3 V	4 A	5 A	3%	--	--	1%
		3	+12 V	2.5 A	4 A	6%	--	--	1%
GLC65H	GLM65H	1	+3.3 V	5 A	8 A	3.5%	± 5%	4.3 ± .8V	1%
		2	+5.0 V	4 A	6 A	4.5%	--	--	1%
		3	+12 V	2.5 A	3 A	6%	--	--	1%

**Notes:**

- A. Continuous individual output ratings for unrestricted convection cooling. Combination of individual output loads must not exceed total power rating.
- B. Peak rating for 60 s 10% duty cycle or continuous rating 150 LFM forced air cooling.
- C. Adjustment on V1 varies all outputs simultaneously (1% on V1 @ 1% on V2 & V3).
- D. Total combined current of V1 & V2 not to exceed 12 A. Combination of individual output loads must not exceed total power rating.
- E. Total regulation is defined as maximum deviation from the initial set point. With all other outputs at 50% load, output under test can be varied from 0 to 100% load and varied to any ac line voltage. Initial set point is 1% on V1, 2% on V2 and 3% on V3

## GLC65/GLM65 MECHANICAL SPECIFICATIONS

J1 INPUT: AMP P/N 640445-3, .156 [3.96mm] CTR, .045 [1.14mm] Square pin header

PIN 3) Ac Neutral  
PIN 2) No Pin  
PIN 1) Ac Line

J2 OUTPUT: AMP P/N 640445-6, .156 [3.96MM] CTR, .045 [1.14MM] Square pin header

PIN 1) Output #2  
PIN 2) Output #1  
PIN 3) Output #1  
PIN 4) Common  
PIN 5) Common  
PIN 6) Output #3

GROUND: .250 X 0.32 Faston Tab  
MATING CONNECTORS: AMP P/N

	AMP HOUSING	CONTACTS
INPUT	640250-3	770476-1
OUTPUT	640250-6	770476-1

WEIGHT: 6.5 OZ. [182 KG]

OPTIONAL CHASSIS/COVER KIT: P/N 08-30466-0065

NOTE: 5 A Maximum recommended current per connector pin convection, 7A with air.

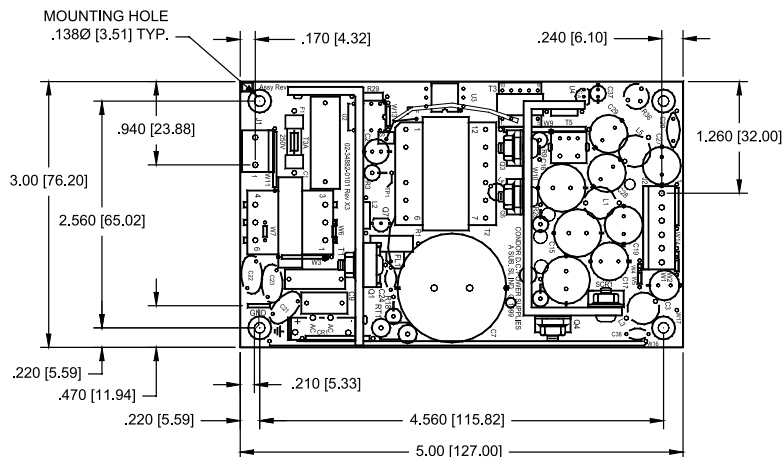

MAX. COMPONENT HEIGHT 1.25 [31.75]  
MAX. LEAD PROTRUSION 0.10 [2.54]

Environmental Specification	Operating	Non-operating
Temperature (A)	0 to 50°C	-40 to +85°C
Humidity (A)	0 to 95% RH	0 to 95% RH
Shock (B)	20 g <sub>pk</sub>	40 g <sub>pk</sub>
Altitude	-500 to 10,000 ft	-500 to 40,000 ft
Vibration (C)	1.5 g <sub>rms</sub> , 0.003 g <sup>2</sup> /Hz	5 g <sub>rms</sub> , 0.026 g <sup>2</sup> /Hz

- A. Units should be allowed to warm up/operate under non-condensing conditions before application of power. Derate output current and total output power by 2.5% per °C above 50°C. Derate output power and current on all outputs by 2.5% per °C. For operation in a confined space, moving air may be required. Under all conditions, the cooling vs. load profile should be such that heat sinks and/or heatsink temperatures do not exceed 90 °C for extended periods.
- B. Random vibration—10 to 2000Hz, 6dB/octave roll-off from 350 to 2000Hz, 3 orthogonal axes. Tested for 10 min./axis operating and 1 hr./axis non-operating.
- C. Shock testing—half-sinusoidal, 10 ± 3 ms duration, ± direction, 3 orthogonal axes, total 6 shocks.